

# MAN ON THE MOON



## milireactor

[www.manonthemoontech.com](http://www.manonthemoontech.com)

The kit consists of a milireactor, and a 1 m piece of high pressure flexible tubing (1/4" O.D.) to connect the reacting gas source (usually a cylinder) and the milireactor via a quick connector. The specifications for the components of the kit permit maximum working temperatures about 150 °C (423 K). Every reactor is tested at 80 barg (1200 psig).

**Warning! High pressure. Work safely**  
**See safety specifications for your reacting gas**



Before starting the experiments, we recommend you to connect the system and check it for leaks at the desired working pressure. This can easily be done by immersing the milireactor under water once assembled and pressurized.

The milireactor has been conceived to avoid exposition of your reaction to air. To this end, prepare your reaction in a 2 mL septum vial under inert gas, connect the milireactor to a Schlenk manifold and close it incompletely, as shown in the left picture (three turns of screw, maximum). Then, evacuate the empty space outside the vial passing through inert gas for several minutes (you may try a cycle of vacuum / inert gas to start the procedure). After, tighten the screw completely, so that the needle can reach the interior of the vial, as shown in the right picture. Now you can apply vacuum to the whole system to evacuate the inert gas (optional) and turn the 3-way valve to pressurize the reaction with the desired gaseous reagent.

The milireactor can be closed by hand, no tools are required.

**Warning!** To release the pressure inside the milireactor you must first open the Schlenk manifold elsewhere, to allow free escape of inert gas. Then, turn the 3-way valve to connect the inside of the reactor and the inert gas circuit. After, you can close the additional inert gas exit, unscrew the reactor and remove the vial from the needle; safely under inert gas.

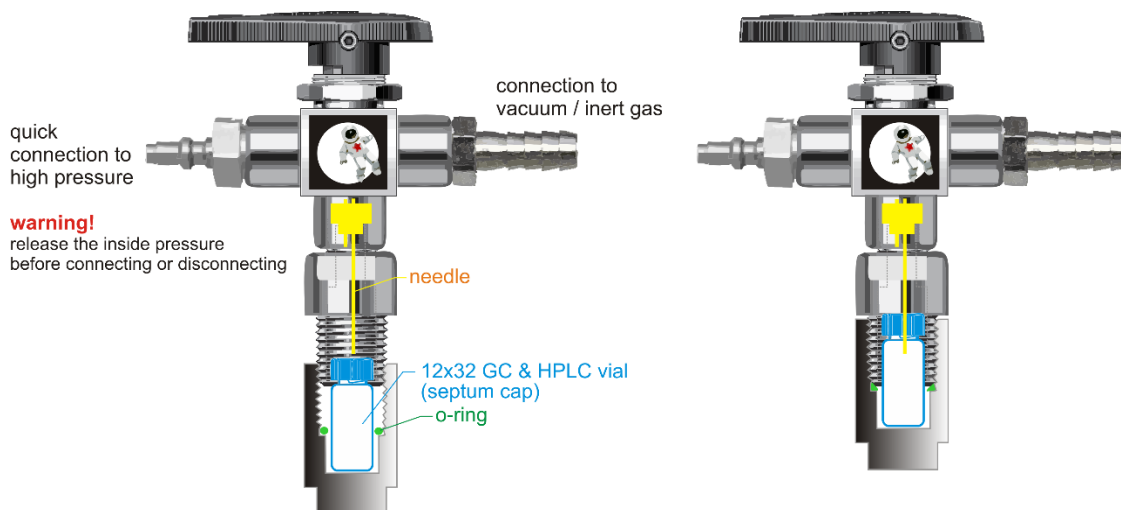

# Technical annex

## 1. Components of the Man on the Moon Milireactor assembly

| Component            | Dimensions (mm) | material                                | Max PS (bar) | Min/Max TS (°C)    |
|----------------------|-----------------|---|--------------|--------------------|
| Reactor body         | see Scheme      | SS 316L                                 | 80           | -                  |
| Body o-ring          | 14 x 2          | NBR (N9002)<br>FKM (V80G2)              | 2000         | -25/100<br>-18/200 |
| Needle o-ring        | 6 x 1           | EPDM (E7502)                            | -            | -45/150            |
| Needle               | 0.5 x 16        | SS 304/306<br>polypropylene             | -            | ---/157            |
| 3-Way valve          |                 | SS 316                                  | 142          | --- /178           |
| Quick connect male   |                 | SS 316                                  | 275          | ---/204            |
| Quick connect female |                 | SS 316                                  | 275          | ---/204            |
| Tubing connection    |                 | SS 316                                  | 275          | ---/204            |
| Tubing connector     |                 | Nickel-plated brass                     | 150          | ---/300            |
| Flexible tubing      | 1000 x 5 (OD)   | Polyurethane /aramid<br>fiber/polyester | 650          | -40/100            |

## 2. Scheme of reactor body

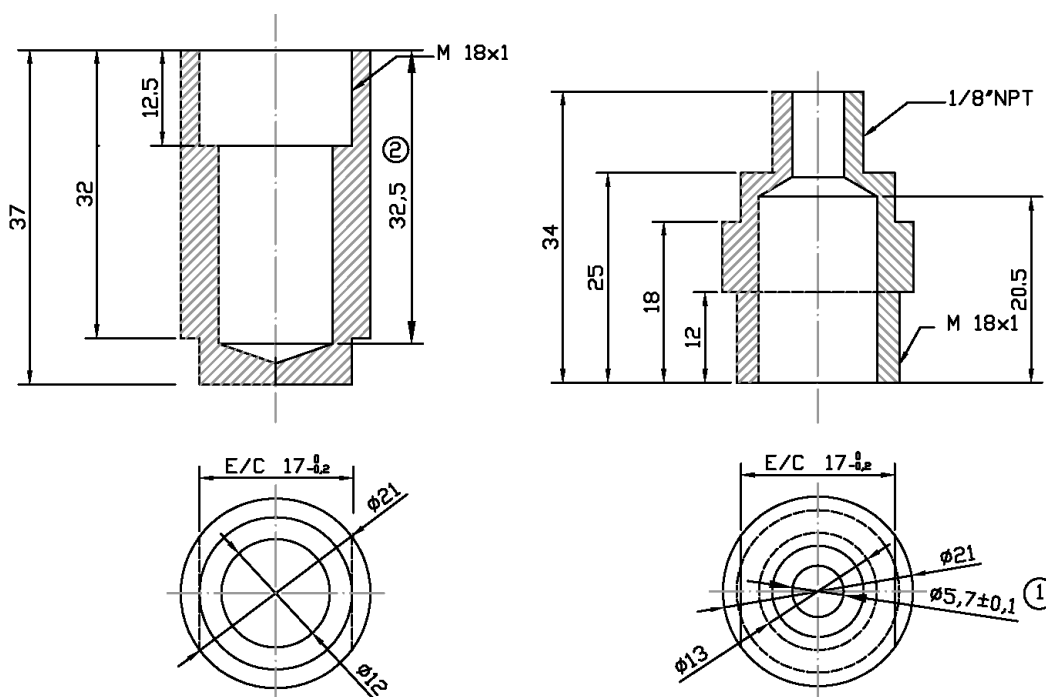

## 3. Pressure and temperature limits

Each milireactor assembly has been tested for pressure resistance by filling it at **80 bar** and immersing in water to readily reveal possible leaks.

Attending to the temperature specifications (TS) of the different components, the recommended maximum reaction temperature is **100 °C**, a limit that can be extended to 150 °C using the green FKM o-ring provided as spare part.

#### 4. Chemical compatibility

Milireactor is designed to host disposable 2 mL vials routinely used in chromatography, provided with septum caps. Most conventional vials consist of type 33 and type 51 COE borosilicate glass and PTFE/silicone septa, which ensures broad chemical compatibility.

During operation, reactions are connected to the milireactor interior (body and 3-way valve) via the internal needle. Milireactor interior is 316/316L stainless steel, which is excellent for use with most organic solvents and commercial gases, but ***non-compatible with halogens and halogen acids***. Inorganic acids (sulfuric, sulfurous, phosphoric and nitric), organic acids and organic halides that can hydrolyze to form inorganic halogen acids, and halogen salts should be used with caution since can cause corrosion problems. Acetic, formic and other organic acids, as well as ammonia and most ammonia compounds are routinely handled in 316 SS.

The internal needle is a standard 16 mm one for conventional syringes, manufactured in 304/306 SS and polypropylene (CAS no. 9003-07-0). It has been chosen for its ubiquity but constitutes the weakest part of the assembly in terms of chemical compatibility and should be routinely inspected and replaced when necessary. Please note that ***the base of the needle needs to be drilled*** before installation to ensure fast pressure equilibration around the glass vial (see the spare one for an example). Its SS part is more sensitive to corrosion compared with the milireactor interior, and the polypropylene base may get damaged after prolonged exposition to some organic solvents.